

StopperSwitch SS3000 Series - Push Buttons

A highly versatile range of attractive switches combining unique design, quality and value. Quick and easy to install, these aesthetically appealing, low/high voltage switches fit any standard UK-type switch socket box.

- StopperPush models are for applications where a momentary push and release activation is desired.
- StopperLatch is ideal for applications where repeat activation must be controlled. Once the switch has been manually activated, it can only be reset by inserting a special key.

All models are available in six colours with space for function marking and operating instructions.

A number of standard models are available for quick delivery but enquiries for custom models are welcomed.

PUSH BUTTON MODELS

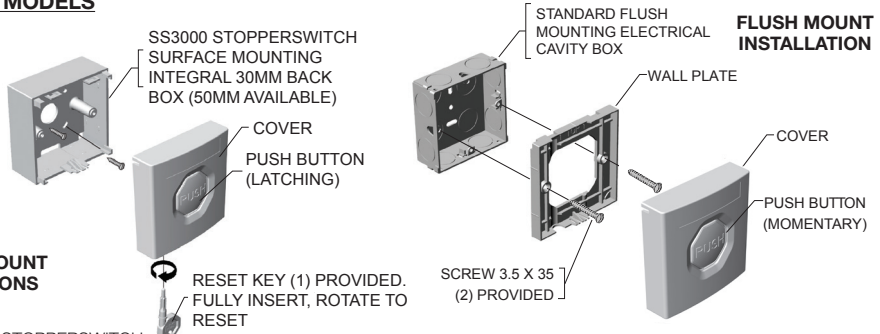

SURFACE MOUNT INSTALLATIONS

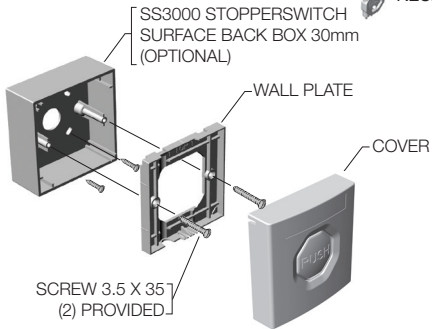

Detaching the cover from the wall plate (Momentary & Latching models)

1. Insert key into the bottom of the StopperSwitch cover.
2. Keep the key inserted and with your hand pull the cover towards you. (As illustrated in Dia. B below)

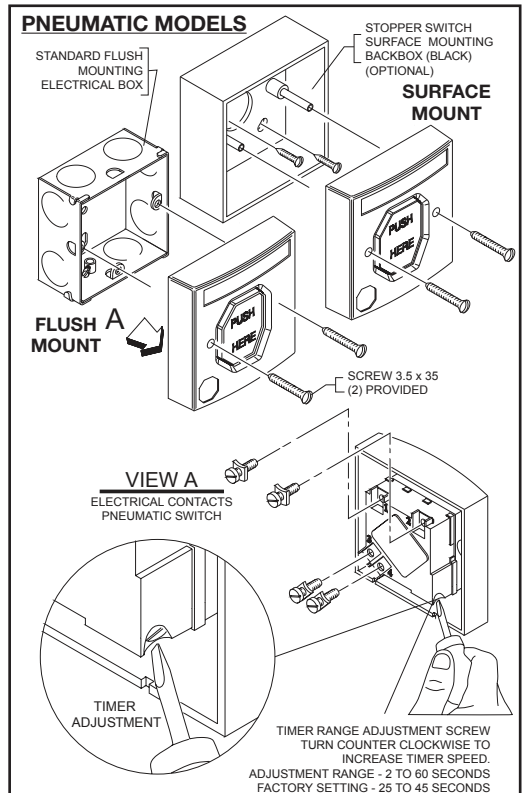
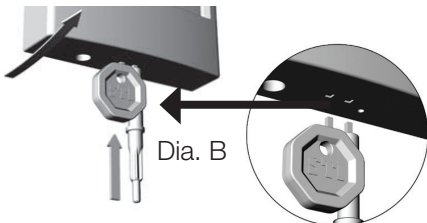

Need help? Call our Technical Support Team on +44 (0)1527 520 999

Installation Data for the StopperSwitch SS3000 Series

Specifications - Push Button Models

Rating	6A 125/250VAC 5A 30VDC (resistive load)
Insulation Resistance	>1250V
Electrical Contact Material	Silver Plated Brass
Housing and Mounting Box Material	Polycarbonate
Installation Terminal Conductor Size	0.5mm - 2.5mm
Operating Temperature	-20°C to +65°C
Colours	Red, Green, Yellow, White, Blue & Orange

Specifications - Pneumatic Models

Current Carrying Capacity (Non switching)	10A (resistive) 240 VAC
Time Range	2 to 60 seconds
Terminals	Solder Type
Timer Life	1,000,000 Operations
Housing Material	PC/ABS
Timer Body	Lexan Plastic
Operating Temperature	-9°C to +49°C
Colours	Red, Green, Yellow, White, Blue & Orange

Methods of Mounting

All StopperSwitch models are supplied as a Dual Mount. Flush or surface installation is achievable with one model.

Flush installations

Secure the wall plate to the flush mount box with the screws provided. Carefully attach the StopperSwitch to the top of the wall plate and hinge down to snap securely into place. (See Dia. B over).

Surface Installations

With the screws provided, fix the back box to the wall and secure the wall plate to the back box. Carefully attach the StopperSwitch to the top of the wall plate and hinge down to snap securely into place. (See Dia. B over).



Dimensions

TOP VIEW

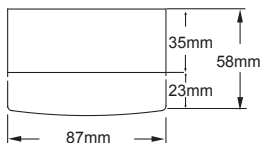

FRONT VIEW

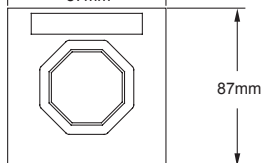

Multi-Function Signal

(Push Button (Latching & Momentary) models)

Denotes a StopperSwitch that incorporates two independent single pole changeover switches providing double pole changeover contacts. Easily accessed through installer terminals as illustrated. Can achieve Single Pole Changeover and Double Pole Changeover.

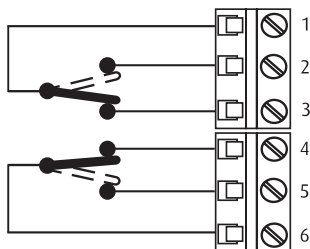

Single Pole Changeover

(Pneumatic models only)

Denotes a StopperSwitch that is fitted with a single pole changeover switch both the normally open and normally closed contacts are easily accessed through the installer terminals as illustrated.

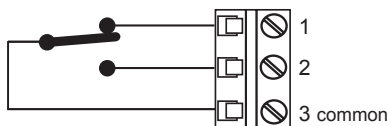

NB: Switch arrangements shown with StopperSwitch in standby.



Safety Technology International
Taylor House, 34 Sherwood Road, Bromsgrove
Worcestershire, B60 3DR, England
Telephone: +44 (0) 1527 520 999
Fax: +44 (0) 1527 501 999
E mail: info@sti-emea.com Web: www.sti-emea.com



IDSS3_Push Buttons • Revised 1020 • Printed in England

Need help? Call our Technical Support Team on +44 (0)1527 520 999