

# Enviro Stopper®

The Enviro Stopper is a protective cover that is especially suited to extending the life and reliability of devices exposed to harsh environmental conditions. It offers protection for both indoor and outdoor applications, as well as preventing tampering, vandalism and damage from accidental operation.

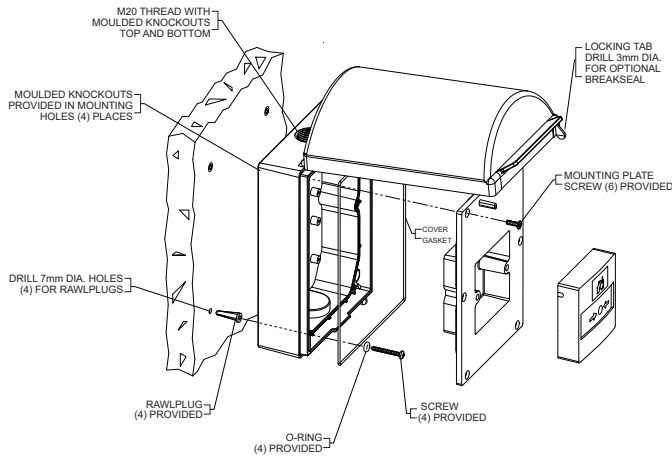

## Open Mounting Plate Installation – (see reverse for enclosed mounting plate installation)

1. Open the front cover of the Stopper and ensure that the mounting plate is removed.
2. Using a 6mm drill bit, create mounting pilot holes in each of the 4 corners of the back box. To achieve this, pass the drill bit down through each of the 4 tubular shafts (situated next to the brass inserts) and drill through the bottom of the base.
3. If routing conduit via the 20mm threaded entry points (top and bottom), knock through a hole at the required end of the back box.
4. It may be advisable to fully attach the conduit to the base unit, using an appropriately rated IP connector before installing the Stopper to the wall; this will ensure a good seal.
5. Position the Stopper, mark & drill 6mm holes into the wall and insert the rawl plugs provided.
6. Before installing the back box, ensure each of the 4 x pan head screws has been passed through one of the small O-rings provided. Line up the mounting holes with the screw holes and secure firmly to the wall, it is important that a good seal is made by the small O-rings to maintain the existing IP rating.
7. If installing the enclosed mounting plate, refer overleaf.
8. Before affixing the open mounting plate to the back box, ensure all of the external wiring has been pulled through the conduit sufficiently into the back box. Now attach the mounting plate using the 6 mounting plate screws provided, ensuring the pour filled gasket is facing down (into the unit) and that the activation pillar is at the top.
9. Make any external connections to the product that is being protected and affix to the mounting plate using the 2 x M3.5 mm screws provided.

## Enclosed Mounting Plate Installation

1. After completing steps 1-6 overleaf, you will need to insert the M25 rubber grommet (provided) onto the back of the enclosed mounting plate.
2. Mark and drill a 25mm hole through the back internal wall of the mounting plate, indicated opposite. It is advisable to do this in the lower half of the recessed section. The grommet has an IP67 rating.
3. Once the hole has been drilled, remove any excess plastic; insert the grommet into the hole, making sure a good seal has been made.
4. Before affixing the enclosed mounting plate to the back box, ensure all of the external wiring has been pulled through the conduit sufficiently into the back box.
5. Pierce a small hole through the centre of the grommet and pass the external wiring through from the back.
6. Now attach the mounting plate using the 6 mounting plate screws provided, ensuring the pour filled gasket is facing down (into the unit) and that the activation pillar is at the top.
7. Make any external connections to the product that is being protected and affix to the mounting plate using the 2 x M3.5 mm screws provided. (an optional rubber gasket is provided, this is designed to be inserted between the mounting plate and the protected product using the mounting holes provided).

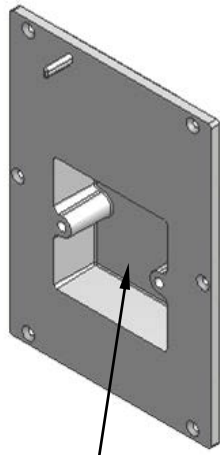

### Important:

It is possible that some water ingress may occur at the front section (cover); whilst any small build-up would accumulate at the bottom of the hinged cover and should not affect the normal working of a product protected by this enclosure, please ensure that all electrical cables are confined to the rear section of this unit. To ensure the product maintains the highest available IP rating, please ensure that good installation practices are followed in accordance with these installation instructions and the parts provided.

### Warranty

Three year guarantee against breakage of polycarbonate in normal use (one year on electro-mechanical and electronic components).

### Installation Tools Required

1. 6mm Masonry drill bit
2. 25mm drill bit (suitable for plastic)
3. Philips screwdriver

Patents:  
United States No. 4267549  
Canada No. 1147828



# Installation Data for the STI 13000 series

## Replacing the battery

1. To replace the battery or alter sounder volume, lift the cover and insert the deactivation pin.
2. Using a small Phillips screwdriver, remove the battery cover and replace battery
3. Select volume using the Hi/Lo switch (96dB/83dB @ 1m).
4. Reassemble the battery cover and screws, then remove the deactivation pin to arm

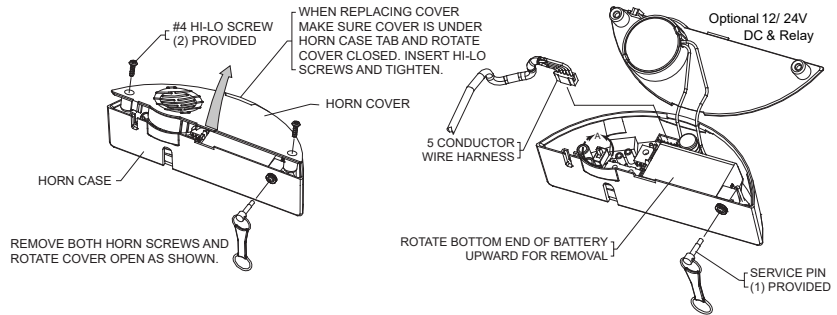

## Fitting the 12/24V DC & Relay Cord

1. When the battery cover is removed, insert the harness cord into the plug and play socket.
2. Leaving a small amount slack, push the harness into the outlet hole, situated on the back of the horn on the left hand side.
3. Attach the battery cover as above, securing the harness.

Wire	Description
Red (+)	+12V - 24V
Black (-)	0V
Blue	Common
Green	NC: Normally Closed
Yellow	NO: Normally Open

## Fixing Points

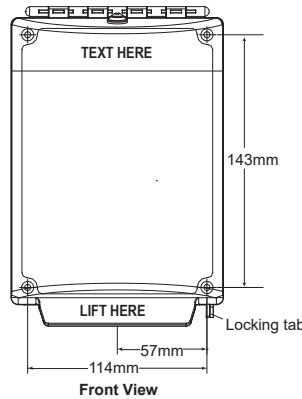

## Specifications

Flammability (cover & frames): UL94 V-2  
Flammability (enclosed backbox): UL94 5VA  
Cover wall thickness = 3mm  
Dry Contact Relay: 30VAC/VDC, 1A

## Alarm Current

Horn	9V battery	12V	24V
Low (83B @ 1m)	40mA	38mA	22mA
High (96dB @ 1m)	105mA	125mA	95mA
Min. Operating Req.	2V @ 20mA	4V @ 20mA	4V @ 20mA

## Dimension Drawings

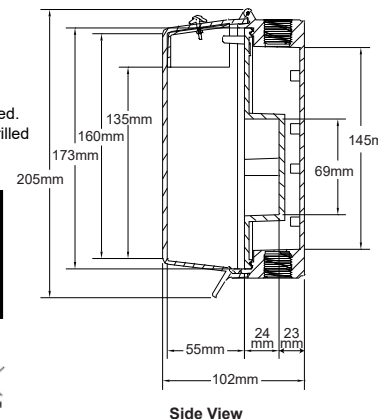
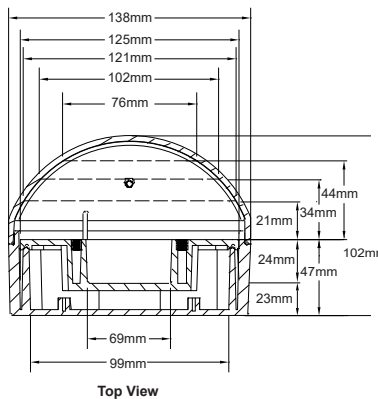

## Caring for Polycarbonate

Rinse with water to remove abrasive dust and dirt. Wash with soap or mild detergent; concentrated solutions and those including (but not limited to) alkalis, strong acids, ethers, amines, aromatic hydrocarbons and alcohols can cause considerable harm to this product. Rinse once more then dry with a soft cloth or chamois. DO NOT use sharp objects that may scratch the surface. Exercise caution when using water inside the enclosure and ensure the unit is completely dry inside before reassembling.

## Temperature Range

Polycarbonate Rated: -40°C to 140°C  
Electronics Operating Range: -40°C to 49°C  
Note: Below -20°C a remote power source is recommended.

## Other Products in the Stopper Range

### Euro Stopper - Slim Line Protective Cover

- STI-15010 Euro Stopper Flush
- STI-15C10 Euro Stopper Surface (32mm)
- STI-15020 Euro Stopper Flush (with sounder)
- STI-15C20 Euro Stopper Surface (with sounder)

NB: 7 colours available. For Red and Green, please refer to Euro Stopper Multi Kit. Blue, Yellow, White, Black and Orange also available, with Custom Label Option.

### Call Point Stopper

- STI-6930 Call Point Stopper Flush
  - STI-6931 Call Point Stopper Surface
- NB: Red, Green and Yellow available.

### Stopper II - Large Retrofittable Protective Cover

- STI-1200 Stopper II Flush
- STI-1230 Stopper II Surface
- STI-1100 Stopper II Flush (with sounder)
- STI-1130 Stopper II Surface (with sounder)

### Weather Stopper II - Large Outdoor Protective Cover

- STI-1250 Weather Stopper II Flush
- STI-3150 Weather Stopper II Surface

### Universal Stopper - Indoor/Outdoor Protective Cover

- STI-13010 Universal Stopper Flush
- STI-13020 Universal Stopper Surface
- STI-13110 Universal Stopper Flush (with sounder)
- STI-13120 Universal Stopper Surface (with sounder)

NB: 6 colours available with choice of label.



**Safety Technology International**

European Office  
Taylor House • 34 Sherwood Road • Bromsgrove  
Worcestershire • B60 3DR • England  
Tel: 44 (0) 1527 520 999 Fax: 44 (0) 1527 501 999  
E-mail: info@sti-emea.com • Web: www.sti-emea.com

USA - Headquarters  
2306 Airport Road • Waterford, Michigan 48327-1209  
Phone: 248-673-9898 • Fax: 248-673-1246  
Toll Free: 800-888-4784 • E-mail: info@sti-usa.com  
Web: www.sti-usa.com