

TOP VIEW

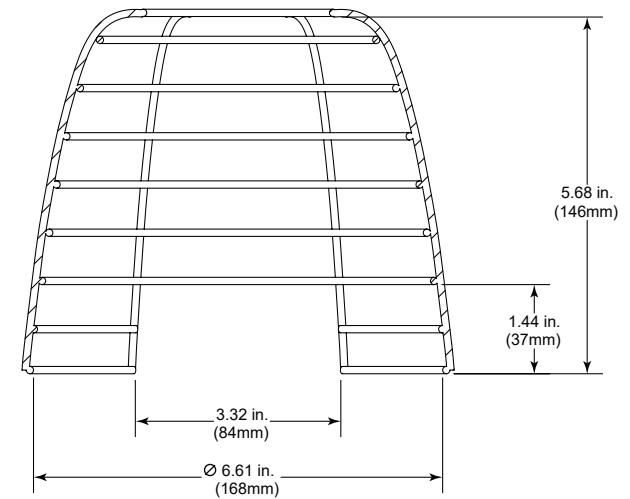

SECTION A-A

INSTALLATION:

1. Centre guard over device.
2. Place first clip in desired location and mount.
3. Locate remaining clips and attach.

INSTALLATION OF STI-9840 Fireray® Fire Detector Damage Stopper®

All specifications and information shown were current as of publication and are subject to change without notice.