

INSTALLATION INSTRUCTIONS

1. Center and place wire guard over device or product to be protected and mark all 6 hole locations with pencil or marker.
2. Drill all 6 holes using 1/4" diameter drill 1-1/2" deep.
3. Insert rawl plugs into drilled holes.
4. Place wire guard in position, insert screws and tighten.

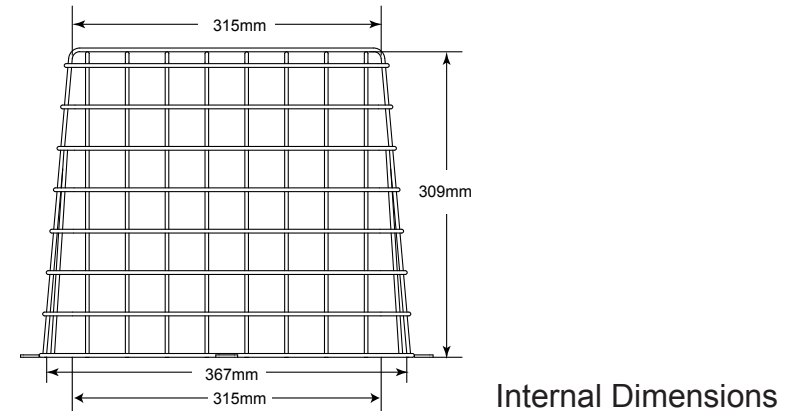
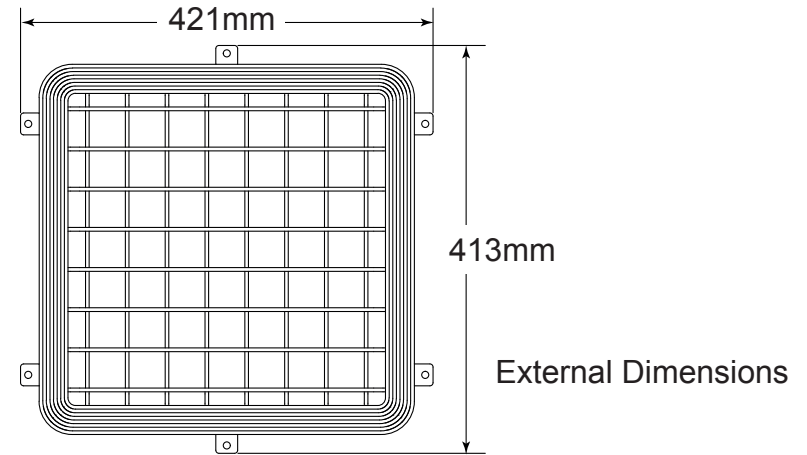

Three year warranty or a one year limited warranty (from date of purchase) on most products. See website for details. Electronic warranty form at www.sti-usa.com/wc14.

INSTALLATION OF STI-9730 WIRE GUARD DAMAGE STOPPER®

All specifications and information shown were current as of publication and are subject to change without notice.

9730 JUL2017

