

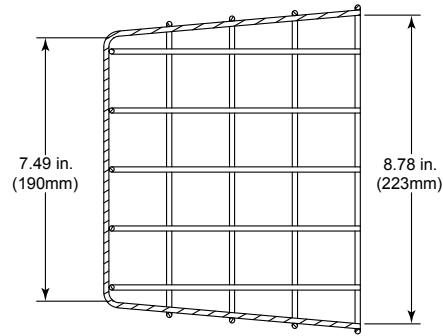

External Dimensions

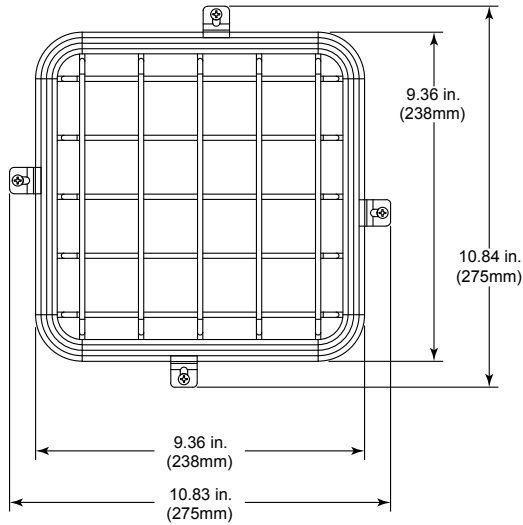

SECTION B-B

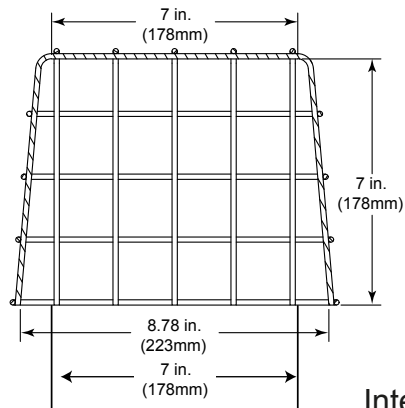
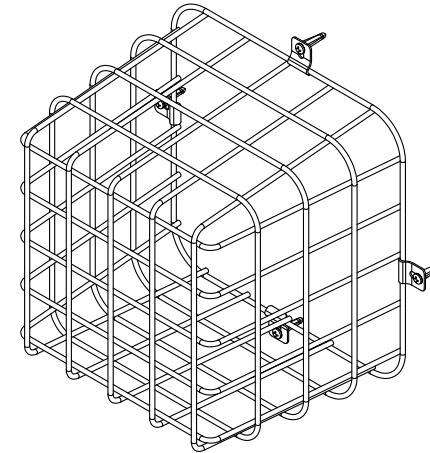

Internal Dimensions

SECTION A-A

INSTALLATION INSTRUCTIONS

1. Center and place wire guard over device or product to be protected and mark all 4 hole locations with pencil or marker.
2. Drill all 4 holes using 1/4" diameter drill 1-1/2" deep.
3. Insert anchors into drilled holes.
4. Place wire guard in position, insert screws and tighten.

Three year warranty or a one year limited warranty (from date of purchase) on most products. See website for details. Electronic warranty form at www.sti-usa.com/wc14.

INSTALLATION OF STI-9729 WIRE GUARD DAMAGE STOPPER®

All specifications and information shown were current as of publication and are subject to change without notice.