

VIEW 1

Install Cabinet

1. Install all Mounting Tabs
2. Place Enclosure in position
3. Mark and drill 1/4" diameter holes
4. Insert #10-12 rawl plugs
5. Mount Enclosure using #10 x 1.5 screws

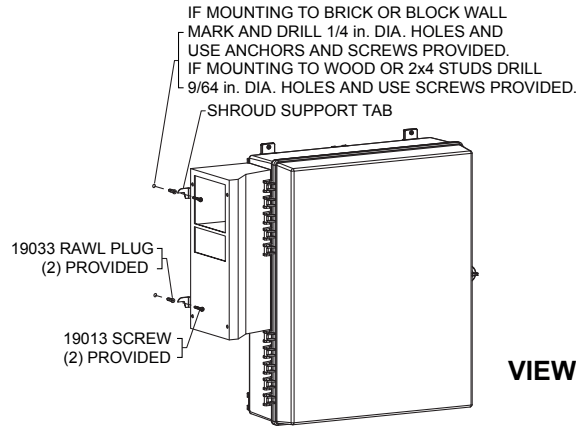

VIEW 2

Locate and Mark Holes for Shroud Support Tabs

1. Place shroud against enclosure cutouts and insert the two top 1/4-20 Socket Head Cap Screws. Hand tighten only.
2. Mark hole locations for the shroud support tabs as shown in View 2.
3. Remove shroud from enclosure and drill holes for shroud support tabs. (See View 2 notes.)
4. Insert rawl plugs and screws. Thread screws in, leaving approximately 1/8" gap between mounting surface and screw head. The shroud support tabs should rest on the screws.

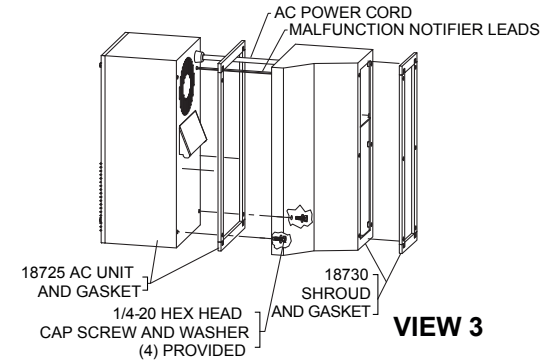

VIEW 3

After 7550 Enclosure has been Mounted

1. Remove adhesive backing and apply AC gasket to AC unit.
2. Place AC power cord and malfunction notifier leads through upper opening of shroud.
3. Mount AC unit to shroud using the (4) 1/4-20 hex head screws and washers. Thread all four hex head screws into AC unit from inside shroud. Hand tighten only until all four screws are in place.
4. Tighten with 7/16 open end wrench.
5. Remove adhesive backing and apply shroud gasket to shroud.

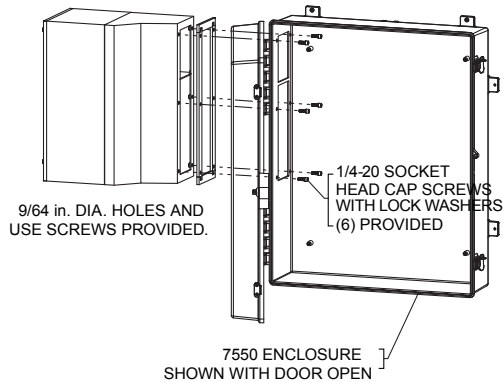

VIEW 4

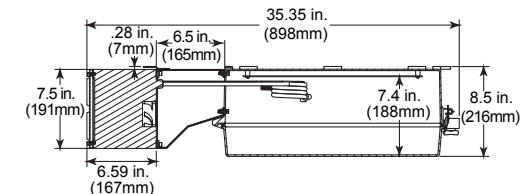
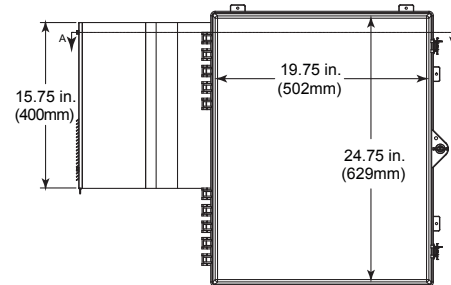

Mount AC Unit and Shroud Assembly to Enclosure

1. Insert AC power cord and malfunction notifier leads through top opening of enclosure cutout.
2. Place AC unit and shroud assembly against enclosure cutouts and rest the shroud support tabs on the two screws previously placed. This will help support the weight of the AC unit.
3. Install all (6) 1/4-20 socket head cap screws and lock washers through enclosure into shroud. Hand tighten only.
4. Now tighten using 3/16" Allen wrench.
5. After AC unit and shroud assembly has been installed, install steel mounting plate to the back inside wall of enclosure using the (4) #8-32 screws provided. (Refer to View 1)

Three year warranty or a one year limited warranty (from date of purchase) on most products. See website for details. Electronic warranty form at www.sti-usa.com/wc14.

INSTALLATION OF STI-7550AC ENCLOSURE

All specifications and information shown were current as of publication and are subject to change without notice.

