

# Exit Stopper®

## Quick Install

STI-6400 Series

Rely on STI®

### SET UP

1. Key in OFF position

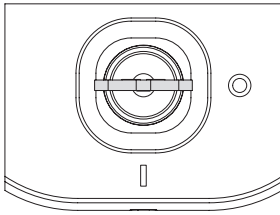

2. Remove security screw with provided wrench

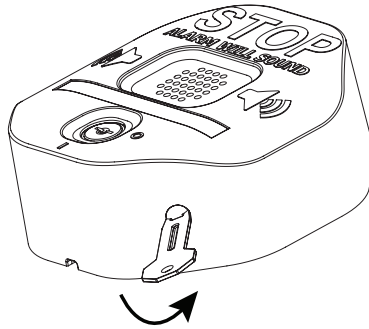

3. Remove cover from base, push on lock to separate

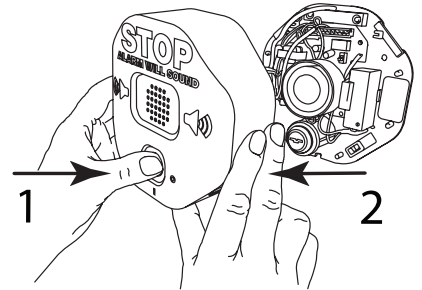

4. Choose setting – refer to switch table, default settings shown side 2

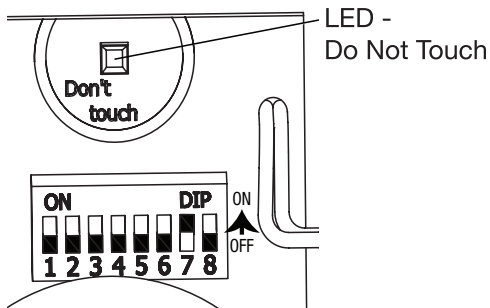

5. Unwrap battery and connect

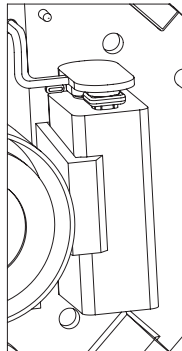

6. Terminal block (for remote and relay options) – refer to full install online for wiring connections

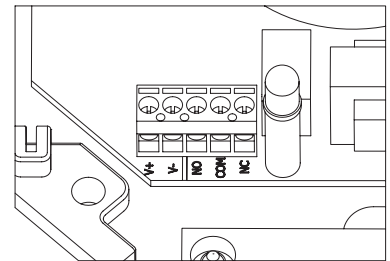

7. Test – place magnet next to reed, turn on, separate magnet from reed

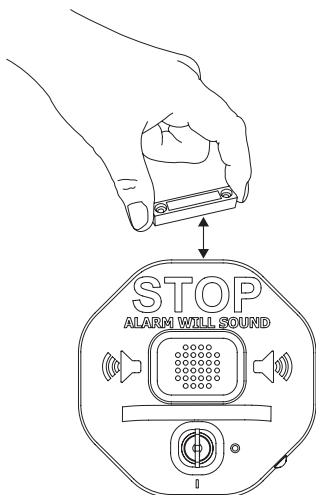

8. Apply language label if desired

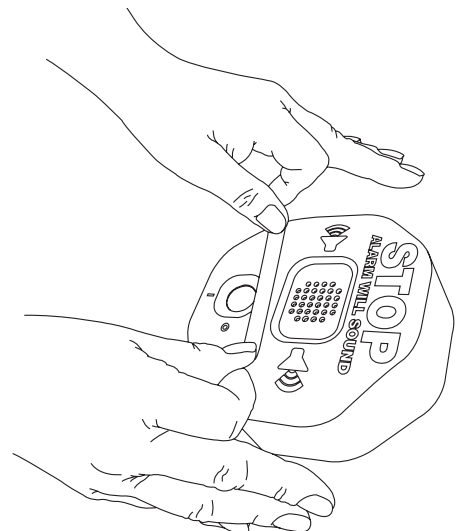

# MOUNTING

- 9.** Place reed at desired location (top, right, bottom or left)

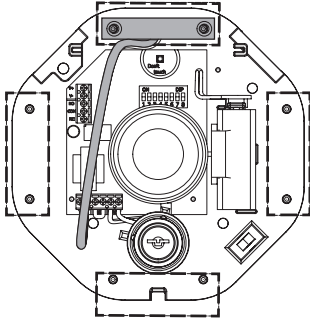

- 10.** Position base. Mark and drill four (4) holes 1" (25mm) deep. Using plastic anchor, drill 3/16" (4.5mm). Install into wood or steel: drill 9/64" (3.5mm). Mount using (4) M4 x 25mm screws.

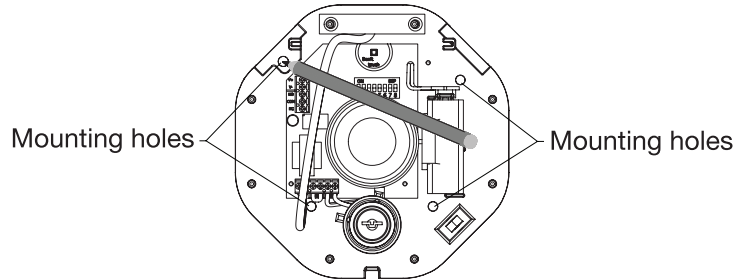

- 11.** Install reed magnet, mark with pencil, drill, install using plastic anchor, drill 3/16" (4.5mm). Install into wood or steel: drill 1/8" (3mm). Mount with (2) M3.5 x 32mm screws.

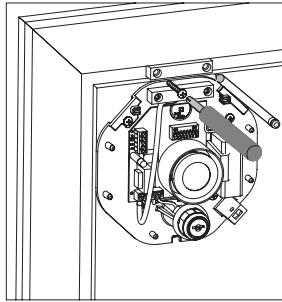

- 12.** Test, turn key on, open door

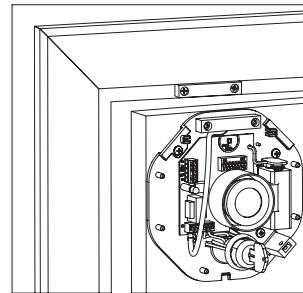

- 13.** Replace cover, snap lid from top, secure with security screw

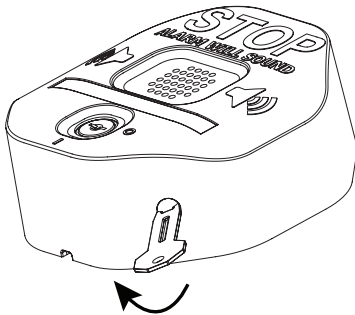

SWITCH SETTINGS	1	2	3	4	5	6	7	8
Arming - immediate	OFF*							
Arming - 15 second delay	ON							
Trip - immediate		OFF*						
Trip - 15 second delay		ON						
Shut-off based on duration (switches 4 & 5)			OFF*					
Shut-off approx. 3 sec. after door closes			ON					
Duration - 30 second alarm				OFF*	OFF*			
Duration - 180 second alarm				OFF	ON			
Duration - continuous alarm				ON	OFF			
Duration - 30 second annunciator mode				ON	ON			
Low battery detection on - Turn switch off						OFF*		
Low battery detection off - Turn switch on						ON		
Volume - high								ON*
Volume - low								OFF
Dry contact relay function → OFF								
Dry contact relay function → ON								ON

\*default

NOTE: Disconnect all power sources before changing switch settings.

OFF\*

## Warranty

Three year warranty or a one year limited warranty (from date of purchase) on most products. See website for details. Electronic warranty form at [www.sti-usa.com/wc14](http://www.sti-usa.com/wc14).

⚠ WARNING: This product can expose you to chemicals including Dichloromethane, which is known to the State of California to cause cancer, and Bisphenol A (BPA), which is known to the State of California to cause birth defects or other reproductive harm. For more information go to [www.P65Warnings.ca.gov](http://www.P65Warnings.ca.gov).



**Safety Technology International**

2306 Airport Rd • Waterford, MI 48327, USA  
 Phone: 248-673-9898 • Fax: 248-673-1246  
 info@sti-usa.com • www.sti-usa.com

Taylor House • 34 Sherwood Road • Bromsgrove, Worcestershire • B60 3DR • England  
 Tel: +44 (0)1527 520 999 • Fax: +44 (0)1527 501 999 • info@sti-emea.com • www.sti-emea.com

Subject to change without notice.

6400 QUICK INSTALL  
 Oct2019