

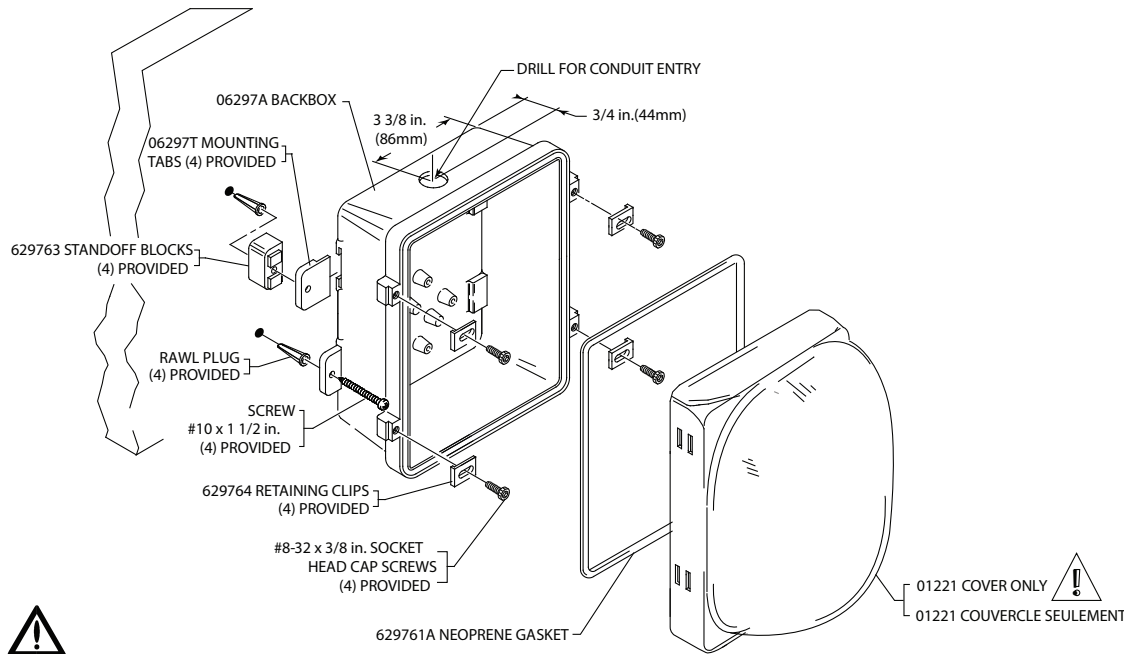

Safety Technology International

USA - Headquarters
 2306 Airport Road • Waterford, Michigan 48327-1209
 Phone: 248-673-9898 • Fax: 248-673-1246
 Toll Free: 800-888-4784 • E-mail: info@sti-usa.com
 Web: www.sti-usa.com

European Office
 Taylor House • 34 Sherwood Road • Bromsgrove
 Worcestershire • B60 3DR • England
 Tel: 44 (0) 1527 520 999 Fax: 44 (0) 1527 501 999
 E-mail: info@sti-emea.com • Web: www.sti-emea.com



INSTALLATION NOTES

1. Damage Stopper must be installed to comply with applicable NEC, NFPA and local codes.
2. In areas where frequent wash downs occur, standoff blocks must be used.
3. Damage Stopper may be installed outdoors when appliance carries an outdoor rating.

REMARQUES SUR L'INSTALLATION

1. Le Stopper de dégâts doit être installé de sorte à être conforme avec les normes NEC, NFPA applicables et les codes locaux.
2. Dans les zones où des jets d'eau fréquents surviennent, des blocs de détection à distance doivent être utilisés.
3. Il est possible d'installer un Stopper de dégâts à l'extérieur lorsque l'appareil est homologué pour utilisation à l'extérieur.

INSTALLATION INSTRUCTIONS - REFER TO EXPLODED VIEW

1. Insert the (4) 06297T external mounting tabs into the frame assembly slots.
2. Using back box assembly as a template, place against mounting surface at proper location according to NFPA 72.
3. Mark and drill (4) holes 1/4 in. (6.3mm) diameter, 1 1/4 in. (32mm) deep.
4. Insert the (4) anchors into the wall.
5. Mount back box to wall with screws.
6. Install electrical fittings as needed.
7. Install strobe appliance.
8. Install cover with clips and screws.
9. Test appliance according to appliance manufacturer's instructions.

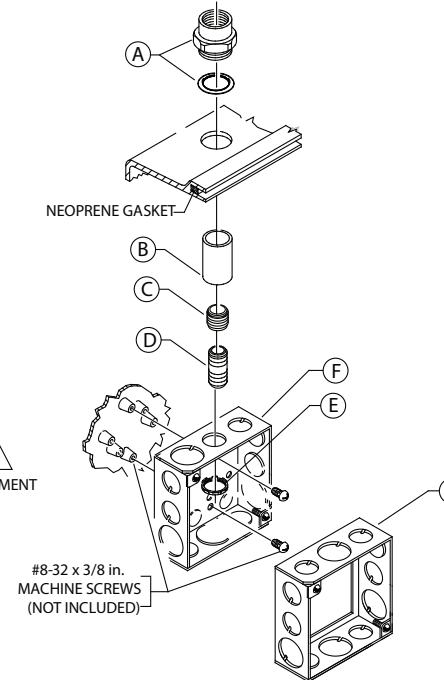

FOR CONDUIT INSTALLATION (NOT INCLUDED)

- "A" Rain-tight hub with neoprene o-ring threaded for 3/4 in. NPT rigid conduit
- "B" 3/4 in. female adapter
- "C" 3/4 in. - 1/2 in. reducing bushing
- "D" Galvanized 1/2 x 1 in. conduit nipple
- "E" 1/2 in. conduit lock nut
- "F" 4 in. square back box
- "G" 4 in. square box extension (optional). Use to extend strobe into cover area.

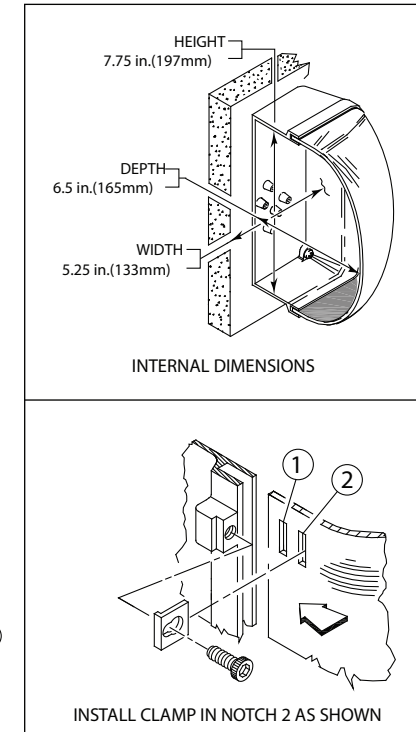

CLEANING INSTRUCTIONS

Rinse with water to remove abrasive dust and dirt. Wash with soap or mild detergent, using a soft cloth (do not scrub). Rinse once more then dry with a soft cloth or chamois. To remove grease or wet paint, rub gently with a cloth wetted with naphtha. Then wash and rinse. **DO NOT USE RAZORBLADES.**

Three year warranty or a one year limited warranty (from date of purchase) on most products. See website for details. Electronic warranty form at www.sti-usa.com/wc14.



INSTALLATION OF STI-1221A4X STROBE DAMAGE STOPPER

All specifications and information shown were current as of publication and are subject to change without notice.

1221A4XIS JAN2017



UL INSTALLATION REQUIREMENTS STI-1210 / STI-1221 SERIES

CAUTION:

- This enclosure is rated to protect signaling appliances indoors and in areas of indirect weather exposure. The cover may be used outdoors only with devices also suitable for outdoor use.
- When covering fire-signaling appliances with this enclosure, some light and sound loss occurs. Please follow these guidelines listed during installation.
- Voice speaker appliance: No spacing adjustment is required for 0.5W, 1.0W and 2.0W appliances.
- Refer to the appliance manufacturer's candela rating. Multiply this number by the light loss value from the chart below to determine the new candela rating. Use this number and refer to the notification layout table of NFPA 72 for proper device locations.
- The use of this cover on audible devices decreases the sound output by 6dB(A). Actual sound level output should be checked after installation to determine if adequate sound levels exist. Refer to the notification layout table of NFPA 72 for proper device locations.

Performance Review LIGHT DERATING FACTOR

Manufacturer	Series	STI-1210	STI-1221 /1221A4x	Manufacturer	Series	STI-1210	STI-1221 /1221A4X
ADT Security	ADTG1-V Series	40%	34%	Honeywell	XLS202 Series	40%	34%
Amseco	SL24W-153075	22%	37%	Honeywell	XLSG1-HV Series	40%	34%
Amseco – Coloured Lenses	SL24W-153075 A,B,G or R	47%	26%	Honeywell	XLSG1-HOV Series	40%	34%
Amseco – Coloured Lenses	SL24C-153075 A,B,G or R	47%	26%	Mircom	FS-240	47%	26%
Amseco – Coloured Lenses	CSL24W-A,B,G or R	47%	26%	Mircom	MS Series	43%	45%
Amseco – Coloured Lenses	CSL24C-A,B,G or R	47%	26%	Mircom	MG1-V Series	40%	34%
Detection Systems	GES24 Series	-	31%	Mircom	MG1-HV Series	40%	34%
Detection Systems	GES24-15/75	-	-	Mircom	MG1-HOV Series	40%	34%
EST/Edwards	2440S Series	43%	45%	Mirtone	MG1-V Series	43%	45%
EST/Edwards	202 Series	43%	45%	National Time&Signal	GES24 Series	-	31%
EST/Edwards	G1-V Series	40%	34%	National Time&Signal	GES24-15/75	-	-
EST/Edwards	G1-HV Series	40%	34%	Potter Electric	AS-24-153075R	47%	26%
EST/Edwards	G1-HOV Series	40%	34%	Potter Electric	AS-24-153075W	47%	26%
EST/Edwards	EG1-V Series	40%	34%	Secutron	GES24 Series	-	31%
EST/Edwards	EG1-HV Series	40%	34%	Secutron	GES24-15/75	-	-
EST/Edwards	EG1-HOV Series	40%	34%	Siemens	202-Series	43%	45%
FaradayLLC	2700	-	57%	Siemens	G1-V Series	40%	34%
Gentex	GES24 Series	-	31%	Siemens	U-MCS Series	-	-
Gentex	GES24-15/75	-	-	System Sensor	SS24110ADA	46%	37%
Harrington Signal	GES24 Series	-	31%	Wheelock	RSS-24MCW	-	-
Harrington Signal	GES24-15/75	-	-	ZitonPly Ltd	ZG1-V Series	40%	34%
Honeywell	XLSG1-V Series	43%	45%				

STI-1210 Series Sound Derating Factor: System Sensor P2, PC2, P4, PC4, SX, SC series models: 6.7 dBA, General: 6 dBA
STI Generic Light Loss Value: STI-1210 Series: 53%; STI-1221 Series: 61%

Safety Technology International, Taylor House, 34 Sherwood Road, Bromsgrove, Worcestershire, B60 3DR, England
Tel. +44 (0)1527 520 999 Fax. +44 (0)1527 501 999 E-Mail. info@sti-emea.com

Rev 01/17-031