

INSTALLATION NOTES

1. TO MINIMIZE STROBE LIGHT LOSS, REGARDLESS OF THE TYPE OF HORN/STROBE APPLIANCE USED, THE CLEAR SECTION (NOT THE SECTION CONTAINING THE CUT OUT SLOTS) MUST BE CENTERED OVER THE STROBE LIGHT LENS. FAILURE TO FOLLOW THESE INSTRUCTIONS MAY LEAD TO LIGHT LOSS TRANSMISSION.
2. DAMAGE STOPPER MUST BE INSTALLED TO COMPLY WITH APPLICABLE NEC, NFPA AND LOCAL CODES.
3. IN APPLICATIONS WHERE WASH DOWNS, RAINFALL OR CONDENSATION OCCUR, IT IS RECOMMENDED THAT A DRAIN OR WEEP HOLE BE PROVIDED. REFER TO WEEP HOLE INSTALLATION DIAGRAM.
4. DAMAGE STOPPER MAY BE INSTALLED OUTDOORS WHEN APPLIANCE CARRIES AN OUTDOOR RATING.

INSTALLATION INSTRUCTIONS - REFER TO EXPLODED VIEW

1. USING ENCLOSURE ASSEMBLY AS A TEMPLATE, PLACE AGAINST MOUNTING SURFACE AT PROPER LOCATION ACCORDING TO NFPA 72.
2. MARK AND DRILL (4) HOLES 1/4 in.(6.3mm) DIA. 1 in.(25mm) DEEP.
3. INSERT THE (4) ANCHORS INTO THE WALL.
4. MOUNT FRAME ASSY. TO WALL WITH SCREWS.
5. INSTALL ELECTRICAL FITTINGS AS NEEDED.
6. INSTALL HORN/STROBE APPLIANCE (EXCEPT FOR RETROFIT APPLICATIONS).
7. INSTALL COVER WITH CLIPS AND SCREWS.
8. TEST APPLIANCE ACCORDING TO APPLIANCE MANUFACTURER'S INSTRUCTIONS.

CLEANING INSTRUCTIONS

- RINSE WITH WATER TO REMOVE ABRASIVE DUST AND DIRT.
- WASH WITH SOAP OR MILD DETERGENT, USING A SOFT CLOTH (DO NOT SCRUB).
- RINSE ONCE MORE THEN DRY WITH A SOFT CLOTH OR CHAMOIS.
- TO REMOVE GREASE OR WET PAINT, RUB GENTLY WITH A CLOTH WETTED WITH NAPHTHA. THEN WASH AND RINSE. (DO NOT USE RAZOR BLADES.)

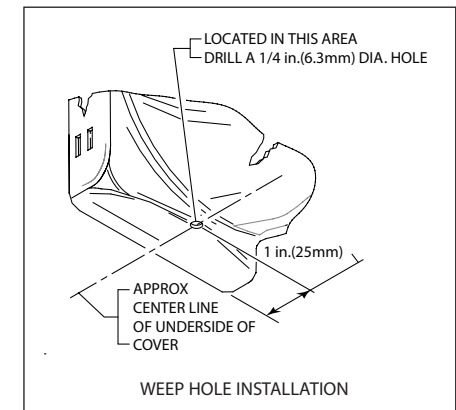

INSTALLATION OF STI-1210E SPEAKER HORN/STROBE DAMAGE STOPPER®

All specifications and information shown were current as of publication, and are subject to change without notice.

1210EIS JAN2017

