

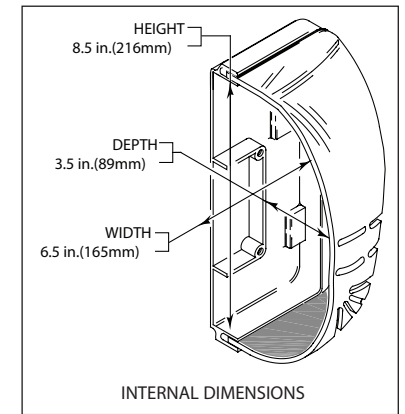

Safety Technology International

USA - Headquarters
 2306 Airport Road • Waterford, Michigan 48327-1209
 Phone: 248-673-9898 • Fax: 248-673-1246
 Toll Free: 800-888-4784 • E-mail: info@sti-usa.com
 Web: www.sti-usa.com

European Office
 Taylor House • 34 Sherwood Road • Bromsgrove
 Worcestershire • B60 3DR • England
 Tel: 44 (0) 1527 520 999 Fax: 44 (0) 1527 501 999
 E-mail: info@sti-emea.com • Web: www.sti-emea.com

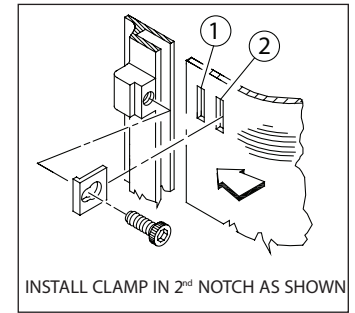
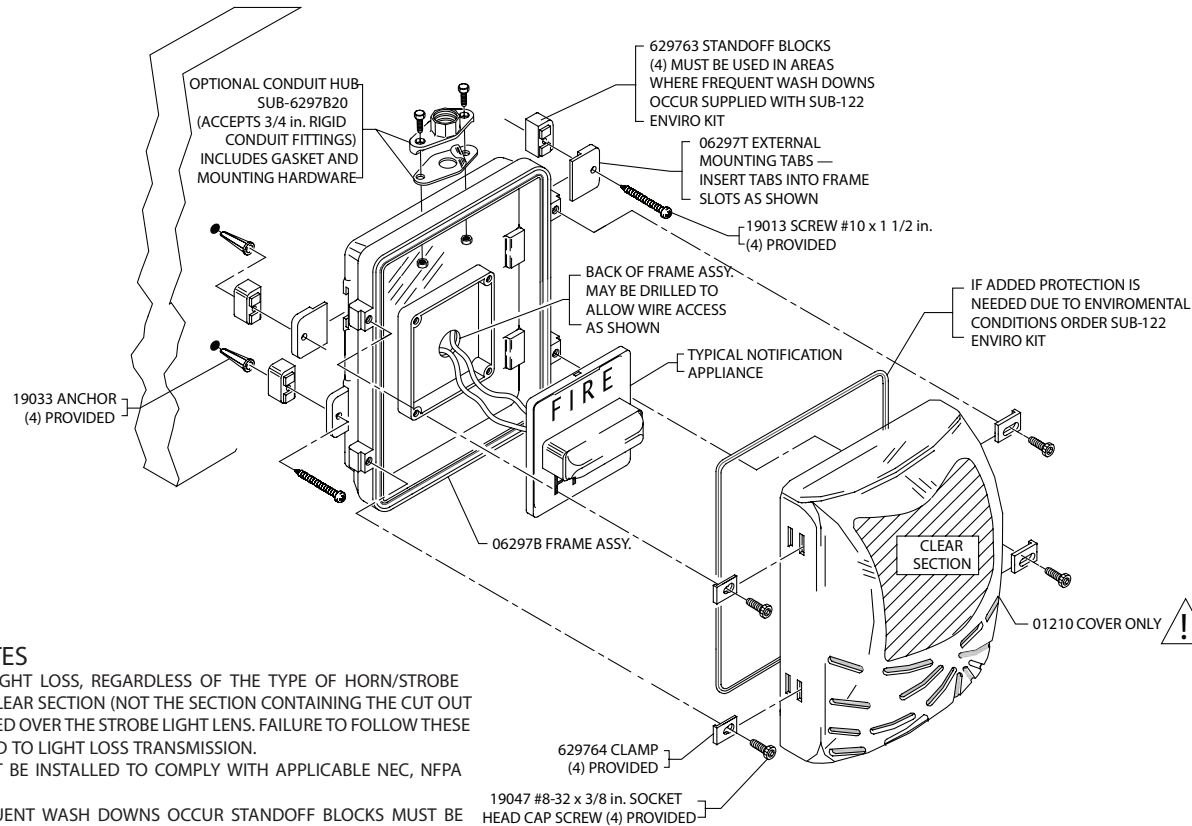

INSTALLATION NOTES

1. TO MINIMIZE STROBE LIGHT LOSS, REGARDLESS OF THE TYPE OF HORN/STROBE APPLIANCE USED, THE CLEAR SECTION (NOT THE SECTION CONTAINING THE CUT OUT SLOTS) MUST BE CENTERED OVER THE STROBE LIGHT LENS. FAILURE TO FOLLOW THESE INSTRUCTIONS MAY LEAD TO LIGHT LOSS TRANSMISSION.
2. DAMAGE STOPPER MUST BE INSTALLED TO COMPLY WITH APPLICABLE NEC, NFPA AND LOCAL CODES.
3. IN AREAS WHERE FREQUENT WASH DOWNS OCCUR STANDOFF BLOCKS MUST BE USED.
4. IN APPLICATIONS WHERE WASH DOWNS, RAINFALL OR CONDENSATION OCCUR, IT IS RECOMMENDED THAT A DRAIN OR WEEP HOLE BE PROVIDED. REFER TO WEEP HOLE INSTALLATION DIAGRAM.
5. DAMAGE STOPPER MAY BE INSTALLED OUTDOORS WHEN APPLIANCE CARRIES AN OUTDOOR RATING.

INSTALLATION INSTRUCTIONS - REFER TO EXPLODED VIEW

1. INSERT THE (4) 06297T EXTERNAL MOUNTING TABS INTO THE FRAME ASSY. SLOTS.
2. USING BACKBOX ASSEMBLY AS A TEMPLATE, PLACE AGAINST MOUNTING SURFACE AT PROPER LOCATION ACCORDING TO NFPA 72.
3. MARK AND DRILL (4) HOLES 1/4 in. (6.3mm) DIA. 1 1/4 in. (32mm) DEEP.
4. INSERT THE (4) ANCHORS INTO THE WALL.
5. MOUNT BACKBOX TO WALL WITH SCREWS.
6. INSTALL ELECTRICAL FITTINGS AS NEEDED.
7. INSTALL HORN/STROBE APPLIANCE.
8. INSTALL COVER WITH CLIPS AND SCREWS.
9. TEST APPLIANCE ACCORDING TO APPLIANCE MANUFACTURER'S INSTRUCTIONS.

CLEANING INSTRUCTIONS

- RINSE WITH WATER TO REMOVE ABRASIVE DUST AND DIRT.
- WASH WITH SOAP OR MILD DETERGENT, USING A SOFT CLOTH (DO NOT SCRUB).
- RINSE ONCE MORE THEN DRY WITH A SOFT CLOTH OR CHAMOIS.
- TO REMOVE GREASE OR WET PAINT, RUB GENTLY WITH A CLOTH WETTED WITH NAPHTHA. THEN WASH AND RINSE. (DO NOT USE RAZOR BLADES.)

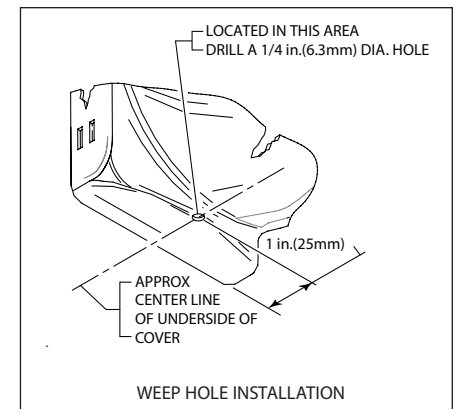

INSTALLATION OF STI-1210B SPEAKER HORN/STROBE DAMAGE STOPPER®

All specifications and information shown were current as of publication, and are subject to change without notice.

1210BIS JAN2017

