

INSTALLATION INSTRUCTIONS

1. Insert the (4) 06297T mounting tabs into the back box slots.
2. Using the back box as a template, place against the mounting surface and mark the location for the mounting screws.
3. Drill (4) 1/4 in.(6.3mm) diameter holes.
4. Insert the (4) plastic anchors provided into the wall.
5. Mount the back box to the wall using the (4) #10 x 1-1/2 in. screws.
6. Connect conduit and pull wire into the back box.
7. Mount the cover assembly to the back box using (4) #8-32 x 3/4 in. socket head screws and (4) #8 flat washers.
8. Lift the cover and pull wires through the cutout of the mounting plate and attach them to the device to be mounted.
9. Mount the device using the (2) #6 x 5/8 in. tapping screws.
10. Close the cover by aligning the (2) tabs on the top of the mounting plate and rotate the cover down to close.

| ITEM | PART NUMBER | DESCRIPTION | QTY |
|------|-------------|---|-----|
| 1 | 6297101-M2 | 06297 SERIES BACKBOX COVER MACHINED TO SPEC. | 1 |
| 2 | 629761A | NEOPRENE GASKET FOR 06297 SERIES BACKBOX | 1 |
| 3 | 06297T | WALL MOUNT TAB | 4 |
| 4 | SUB-51 | 05101 HORN HOUSING WITH "IN CASE OF FIRE..." LABEL | 1 |
| 5 | SUB-50 | 01002 BUBBLE COVER WITH "LIFT HERE" LABEL | 1 |
| 6 | 06297A-M1 | "A" BACKBOX WITH (1) CONDUIT HUB HOLE | 1 |
| 7 | 18021 | 3/4 in. NPT NEMA 4X CONDUIT HUB | 1 |
| 8 | | #8-32 x 5/8 in. BUTTON HEAD SCREW WITH SEALING WASHER | 1 |
| 9 | | #8 U-TYPE NUT | 1 |
| 10 | | #8-32 x 1/2 in. TRUSS HEAD TAMPER SCREW | 2 |
| 11 | 18056 | SOLDERLESS WIRE CRIMP CONNECTOR WITH EYE LOOP | 2 |
| 12 | | #8-32 KEPS HEX NUT | 2 |
| 13 | SUB-05-M1 | LANYARD | 1 |
| 14 | | #8-32 x 3/4 in. SOCKET HEAD CAP SCREW | 4 |
| 15 | | #8 FLAT WASHER | 4 |
| 16 | | #10 x 1-1/2 in. PHIL PAN HEAD SCREW | 4 |
| 17 | | #10-12 PLASTIC ANCHOR | 4 |
| 18 | | #6 x 5/8 PHIL PAN HEAD HILO TAPPING SCREW | 2 |
| 19 | 629763 | 1/2 in. BACKBOX TAB SPACER | 4 |

IMPORTANT NOTE: FOR WET OR WASHDOWN AREAS, STI RECOMMENDS DRILLING (2) 1/8 in. (3mm) DIAMETER WEEP HOLES IN THIS AREA TO PREVENT THE BUILD-UP OF WATER INSIDE THE ENCLOSURE WHICH MAY CAUSE DAMAGE TO ELECTRONIC COMPONENTS

AVIS IMPORTANT: DANS LE CAS DES ZONES HUMIDES OU À APPLICATIONS SANITAIRES, STI RECOMMANDE LE PERÇAGE DANS CES ZONES DE DEUX (2) BARBACANES DE 1/8 PO (3 MM) DE DIAMÈTRE AFIN D'ÉVITER L'ACCUMULATION D'EAU DANS LE BOÎTIER, CE QUI RISQUE D'ENDOMMAGER LES COMPOSANTS ÉLECTRONIQUES

CLEANING INSTRUCTIONS

1. Rinse cover with water to remove abrasive dust and dirt.
2. Wash with soap or mild detergent using a soft cloth. (DO NOT SCRUB.)
3. Rinse once more, then dry with a soft cloth or chamois.
4. To remove grease or wet paint, rub gently with a cloth wetted thoroughly with naphtha, then wash and rinse. (DO NOT USE RAZOR BLADES.)

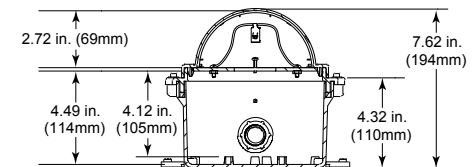
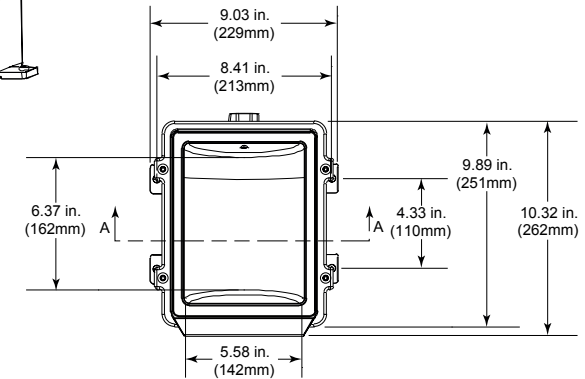
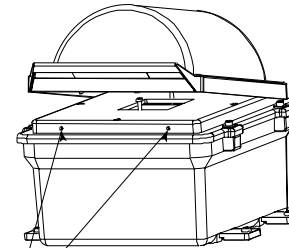

Three year warranty or a one year limited warranty (from date of purchase) on most products. See website for details. Electronic warranty form at www.sti-usa.com/wc14.



INSTALLATION OF STI-1200A STOPPER II with 'A' Back Box

All specifications and information shown were current as of publication and are subject to change without notice.

